



T 973

Seven Channel Amplifier

PRELIMINARY SCHEMATICS

ISSUE DATE: May 2004

Preliminary

T 973 WIRING DIAGRAM

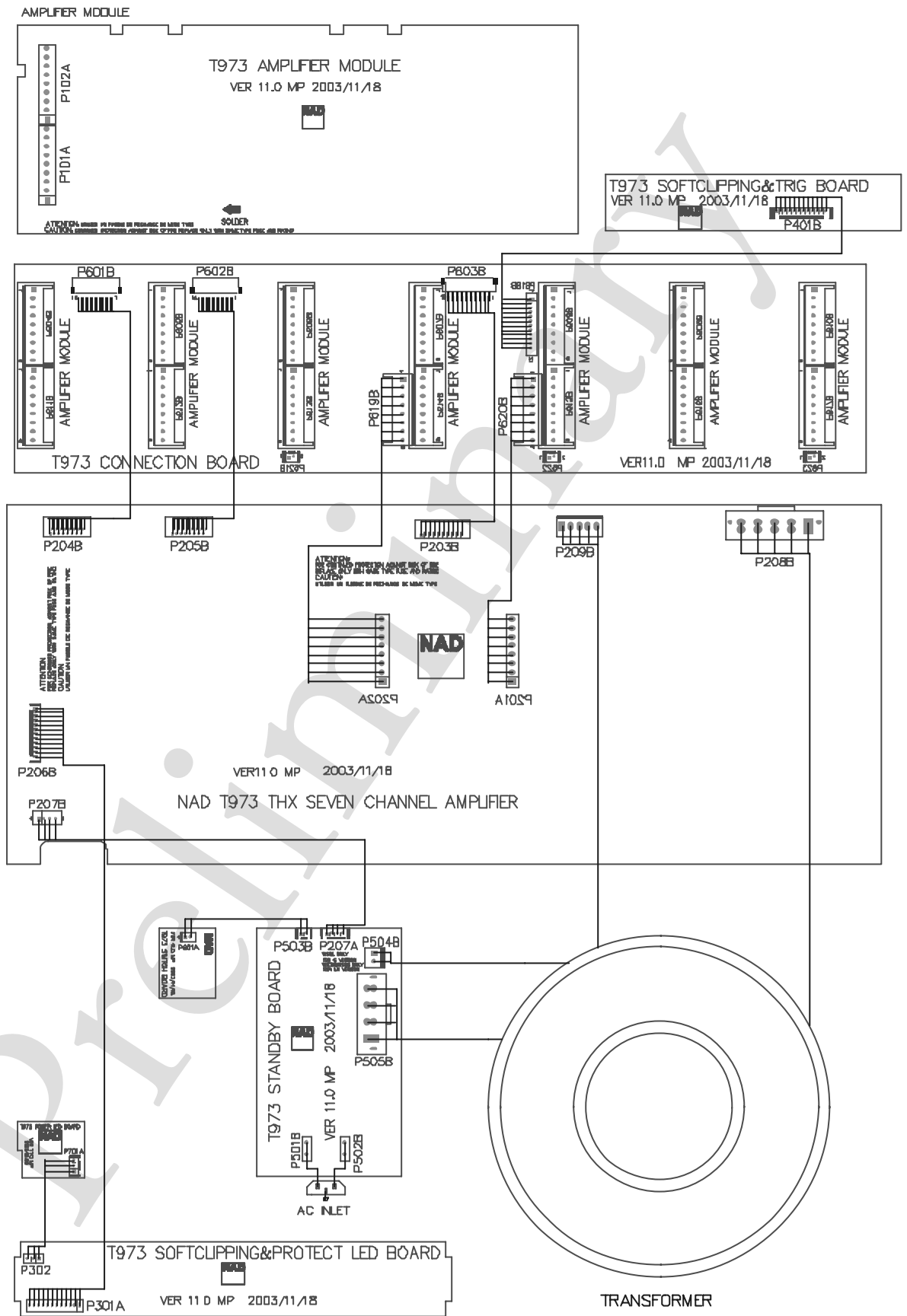

SCHEMATIC DIAGRAM (AMP CONNECTION)

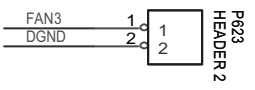
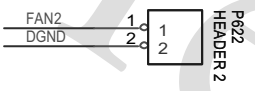
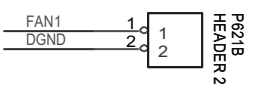
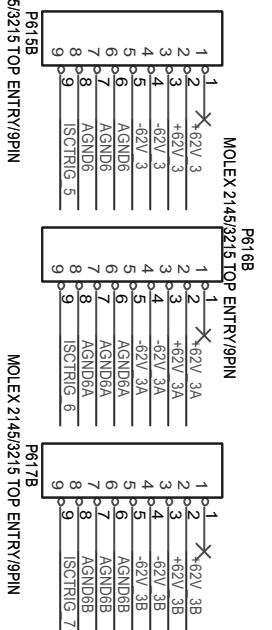
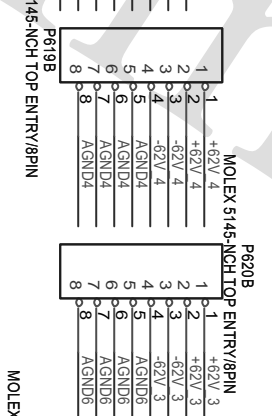
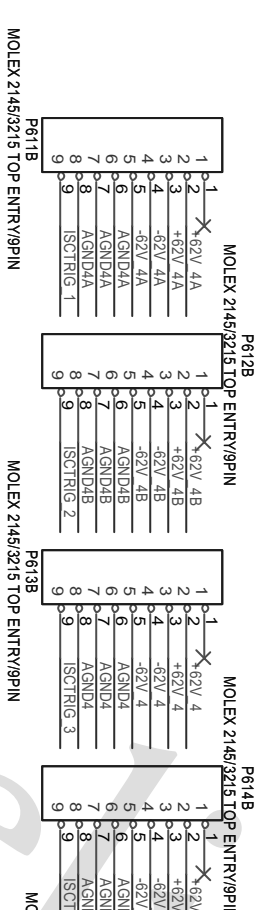
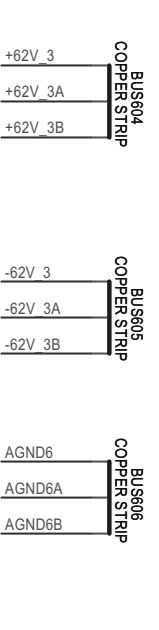
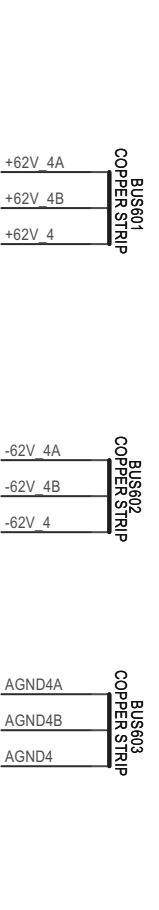
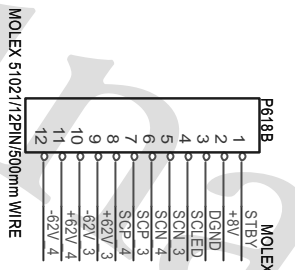
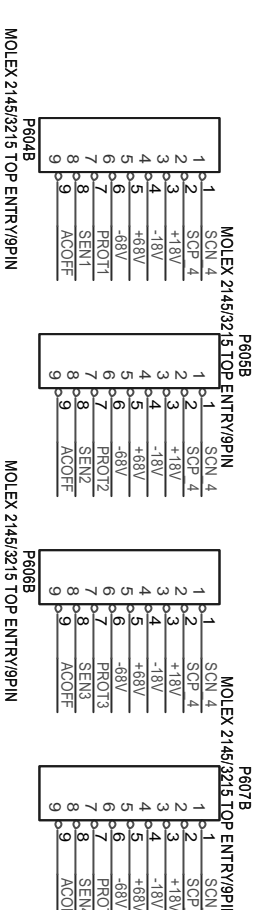
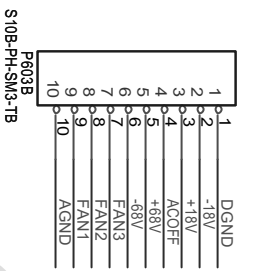

SCHEMATIC DIAGRAM (AMP POWER SUPPLY)

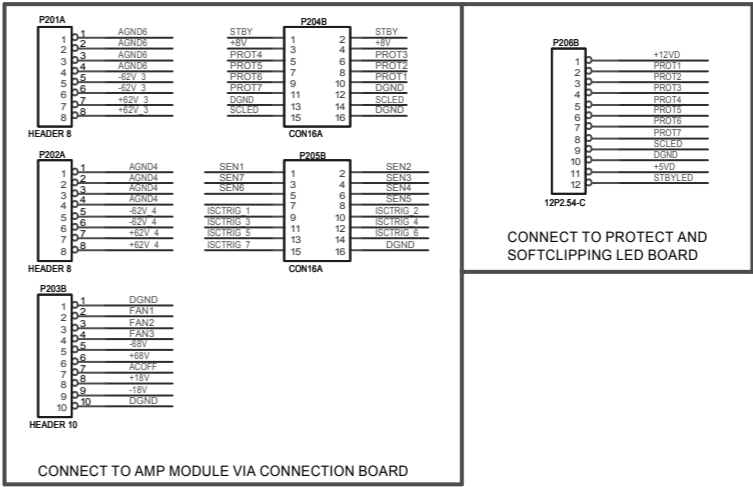
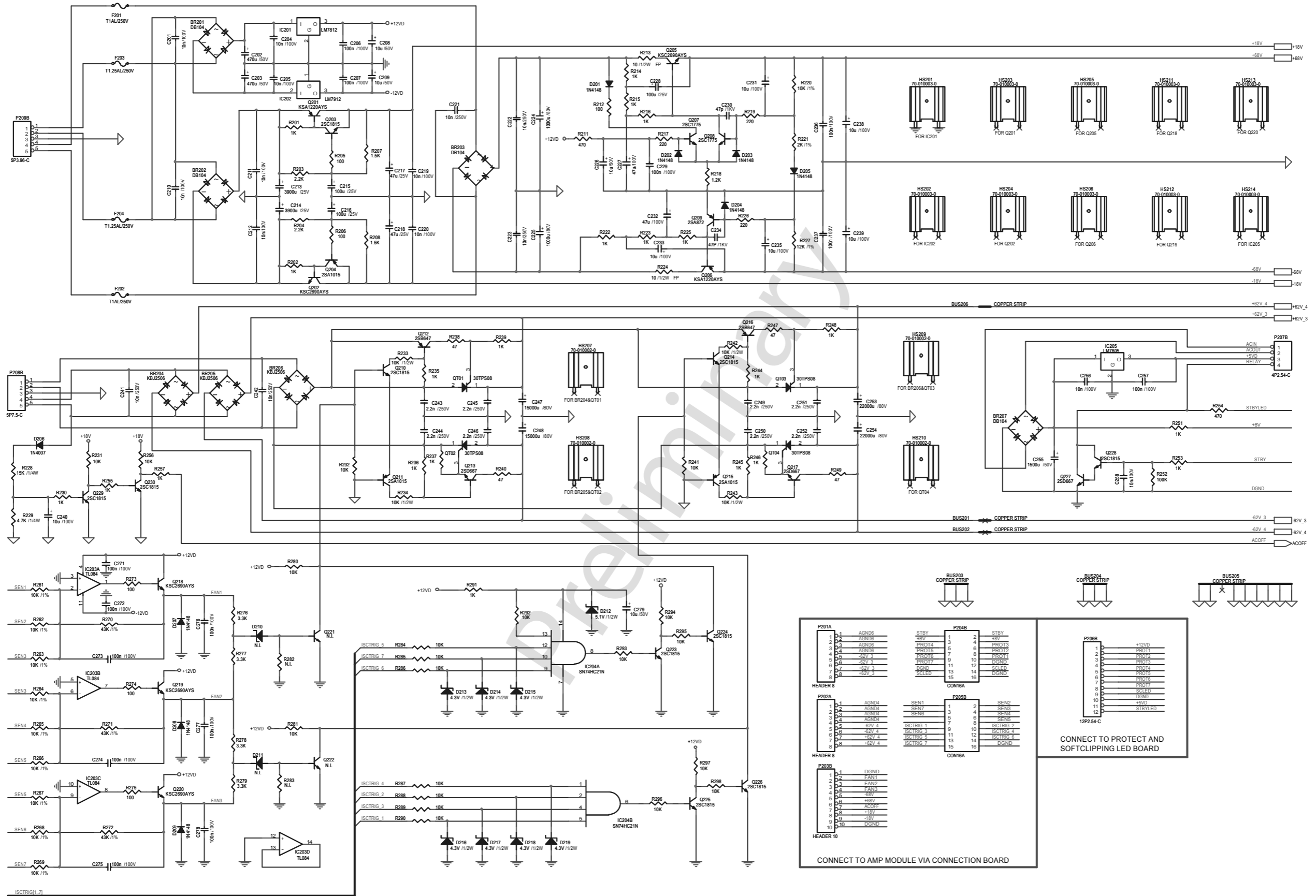

SCHEMATIC DIAGRAM (AMP STANDBY)

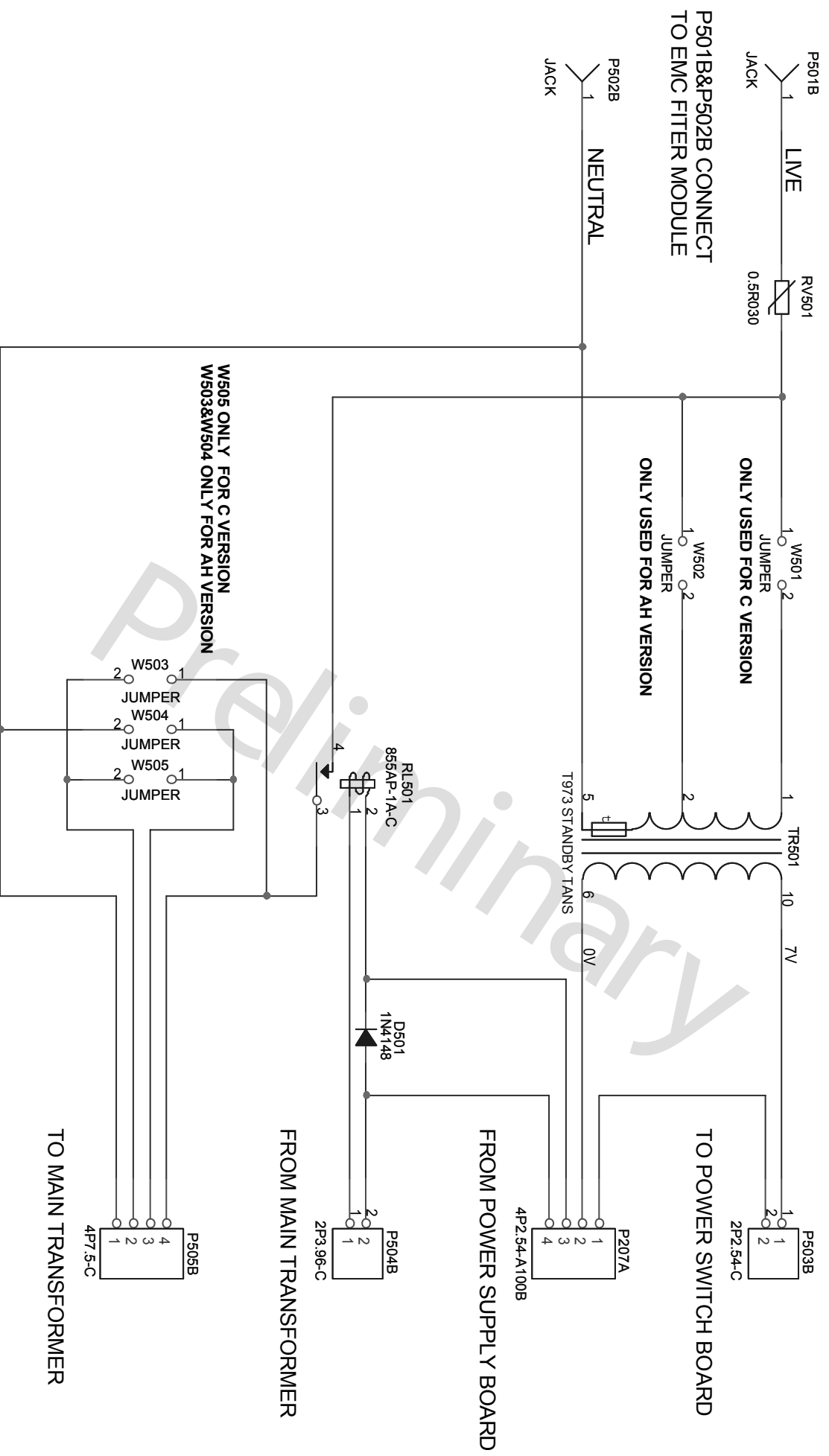

SCHEMATIC DIAGRAM(AMP SOFTCLIPPING AND PROTECT LED)

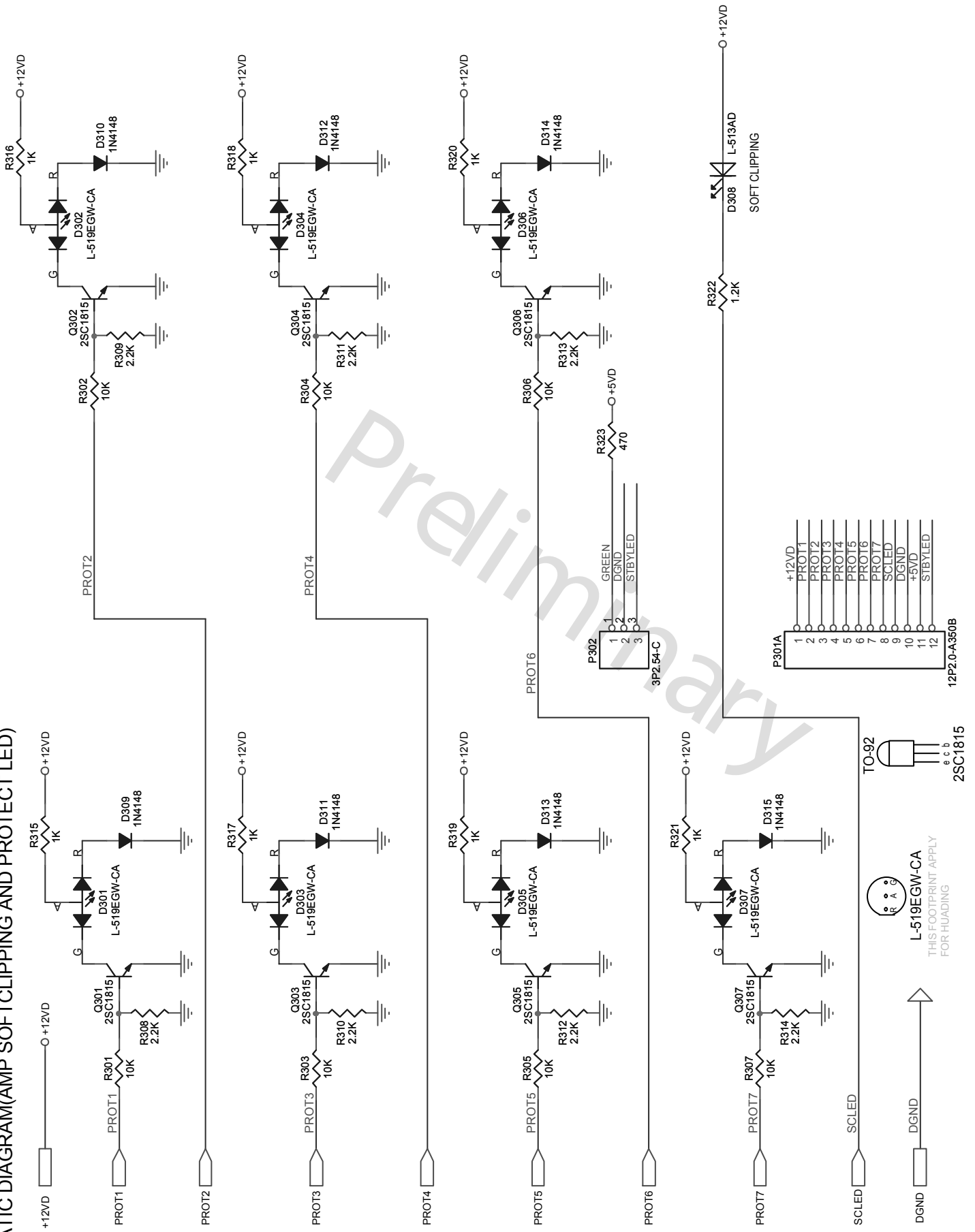

L-519EGW-CA
THIS FOOTPRINT APPLY
FOR HUADING

TO-92
e c b
2SC1815

1	+12VDC
2	PROT1
3	PROT2
4	PROT3
5	PROT4
6	PROT5
7	PROT6
8	SCLD
9	DGND
10	+5VDC
11	STBYLED
12	STBYLED

12P2.0-A350B

1	GREEN
2	DGND
3	STBYLED

3P2.54-C

SCHEMATIC DIAGRAM (AMP SOFTCLIPPING AND AUTO TRIGGER)

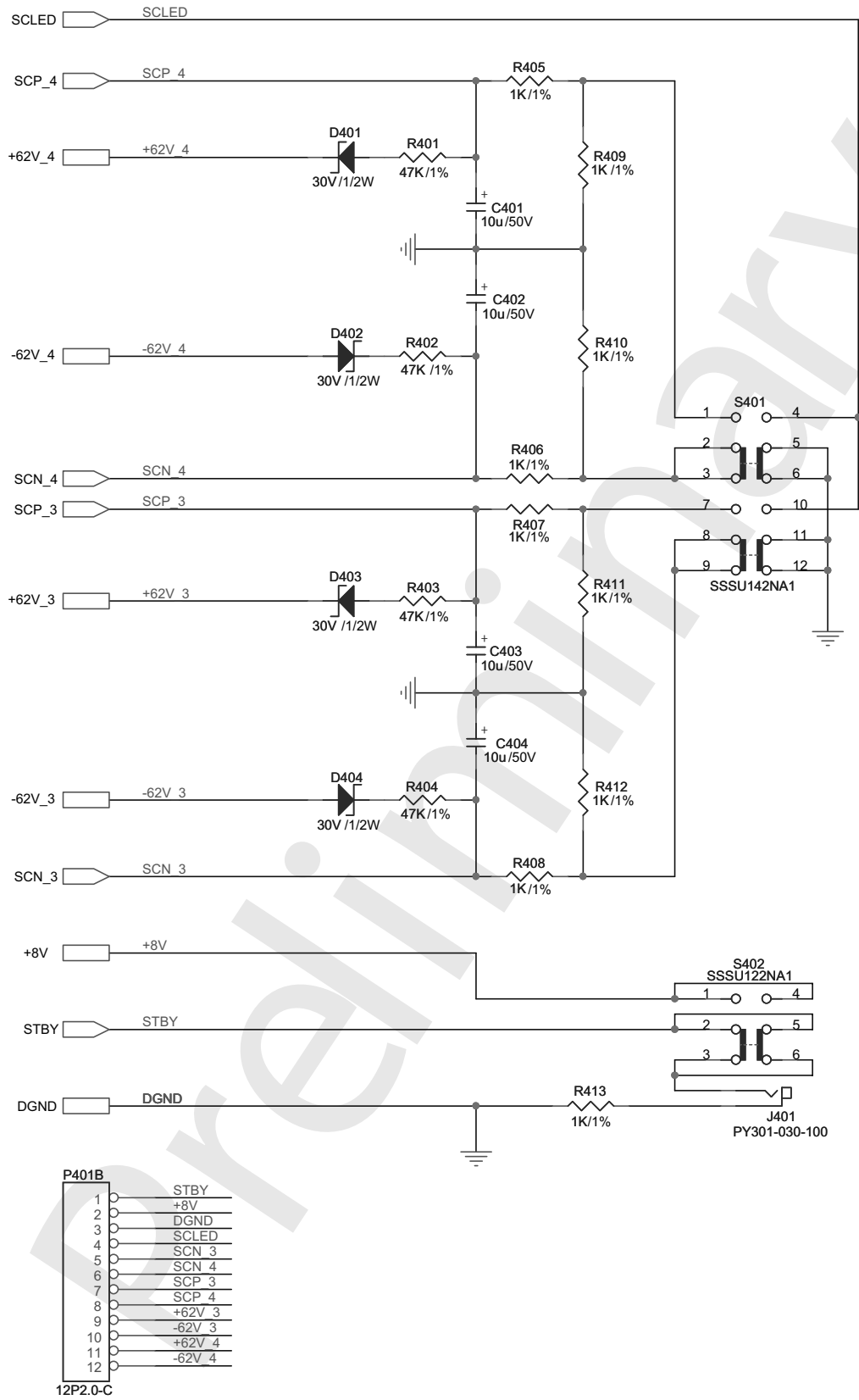

SCHEMATIC DIAGRAM (AMP 1/2)

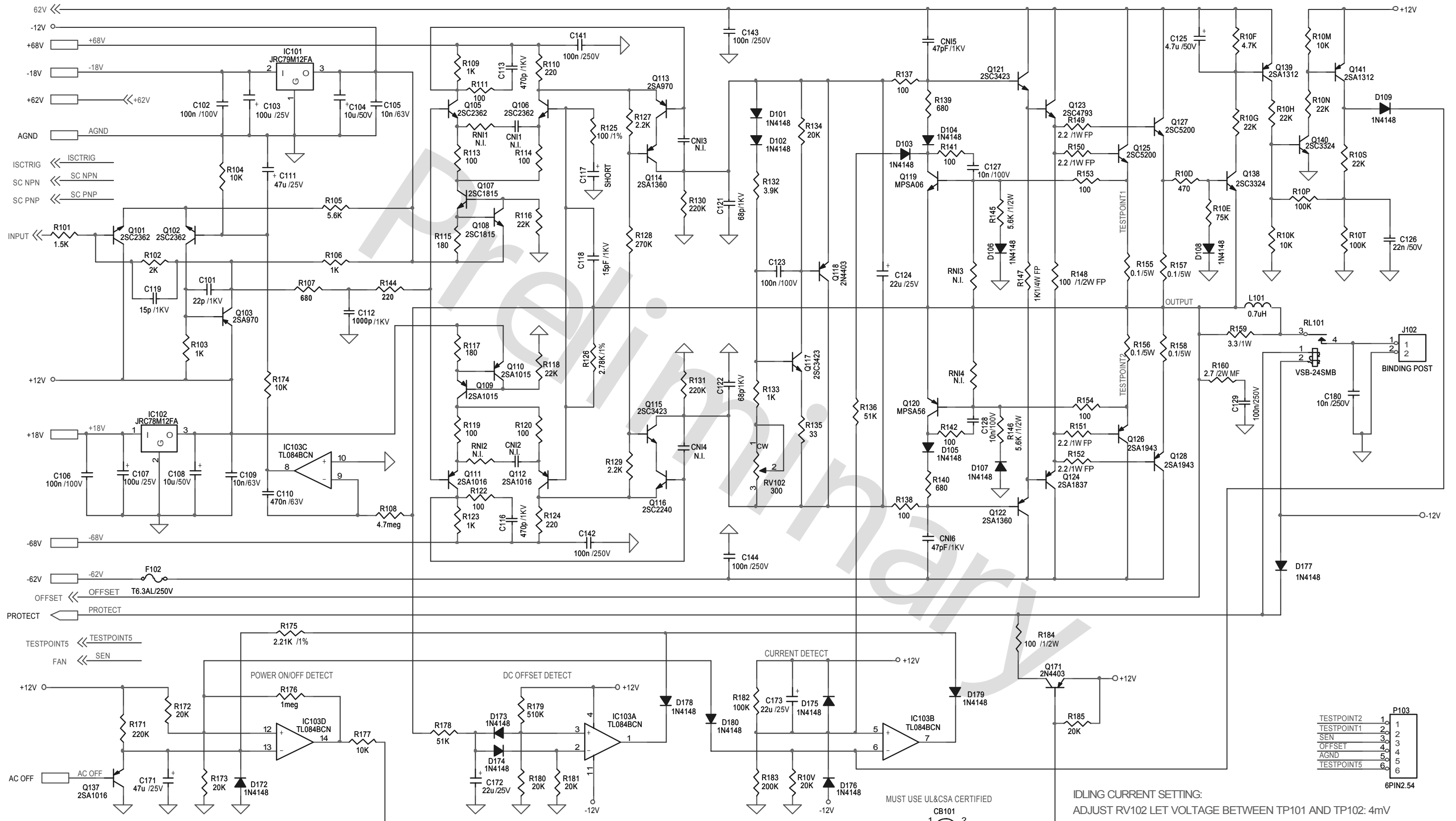

IF CHANGE Q137 TO 2SA970, Please change C171 to 22uF/25V together.

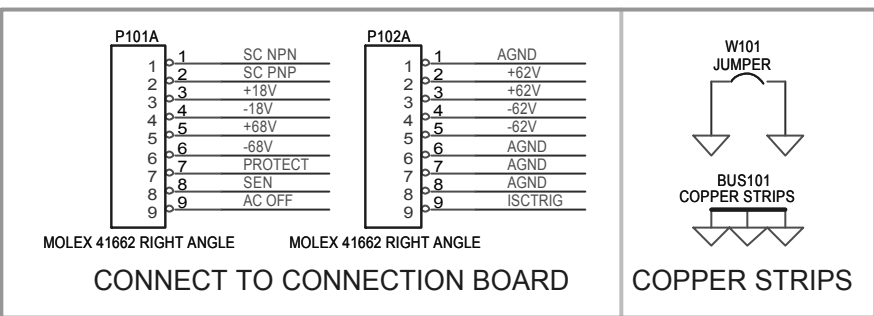
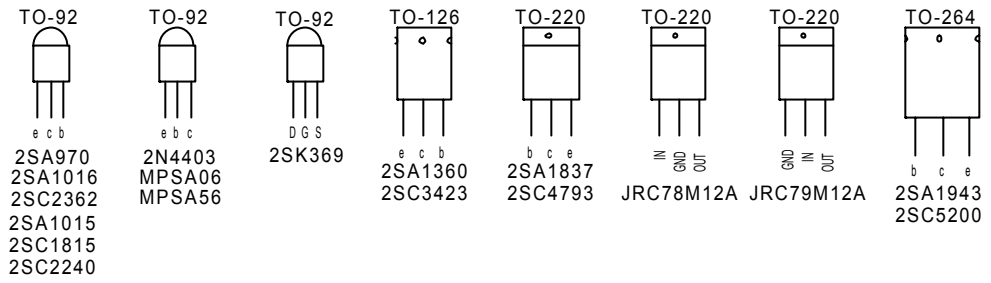

IDLING CURRENT SETTING:
 ADJUST RV102 LET VOLTAGE BETWEEN TP101 AND TP102: 4mV

FAN&ISC SENSITIVITY SETTING
 ADJUST RV103 LET VOLTAGE AT SEN PORT: +300mV

RESISTORS ARE CARBON FILM 1/6W UNLESS SPECIFIED

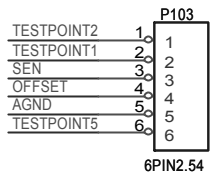

SCHEMATIC DIAGRAM (AMP 2/2)

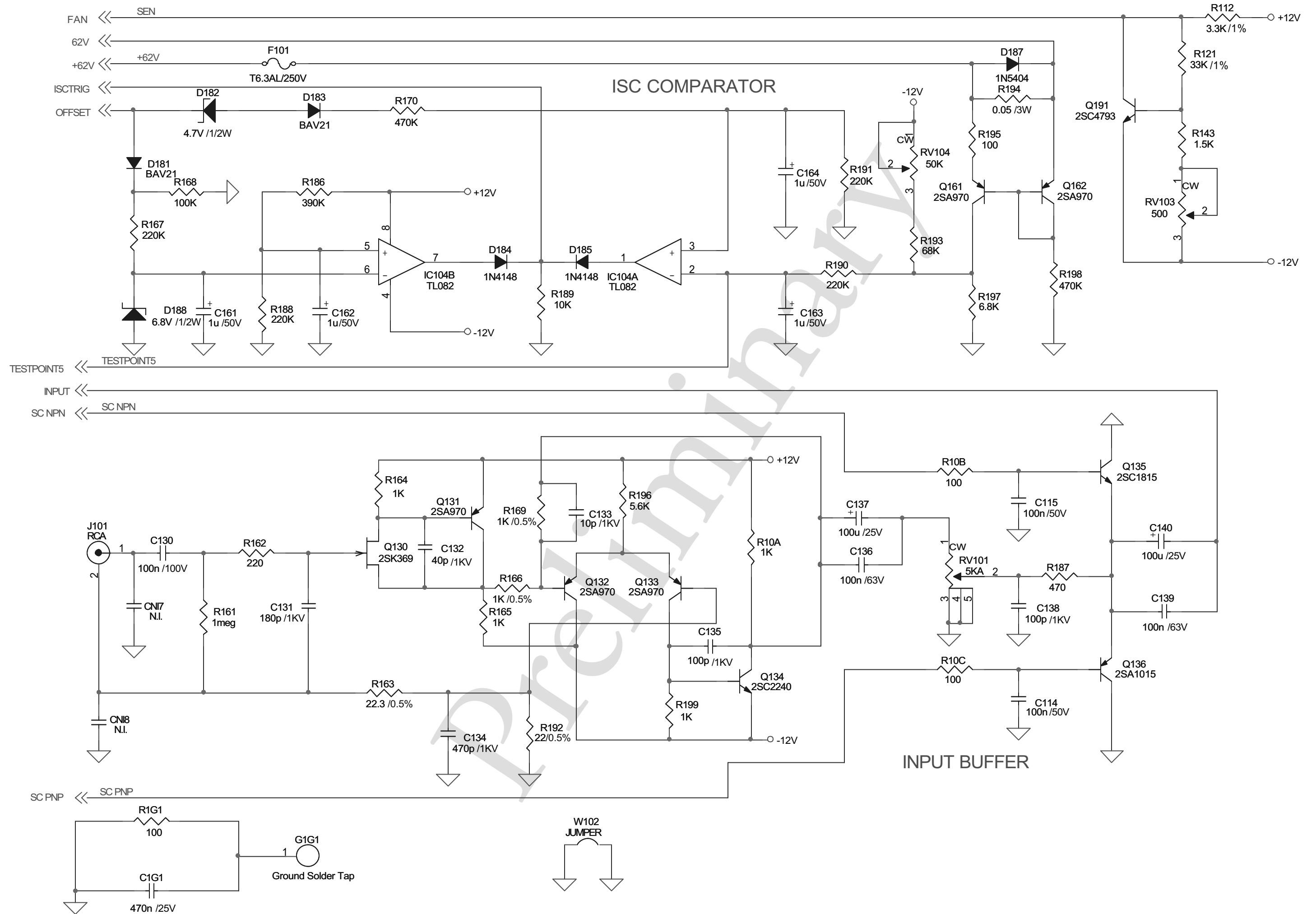

SCHEMATIC DIAGRAM (AMP POWER SWITCH)

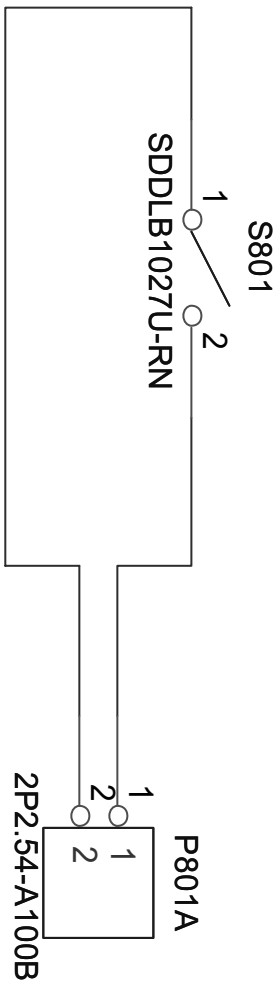

SCHEMATIC DIAGRAM (AMP POWER LED)

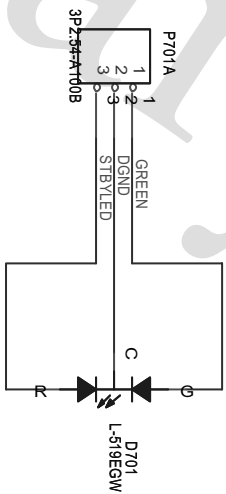

L-519EGW
THIS FOOTPRINT APPLY
FOR HUADING



Preliminary

EXPLODED VIEW PARTS LIST

REF.NO	PART NO.	DESCRIPTION	Qty.	REF.NO	PART NO.	DESCRIPTION	Qty.
C001	66-010001-0	Chassis	1	F005	77-001007-1	Power Button Bezel	1
C002	66-010006-0	Bracket 1	1	F006	76-003001-0	LED Lens	9
C003	01-97306-00	Assembled Connection PCB	1				
C004	66-010008-0	Bracket 3	2	T001	66-010002-0	Top Cover	1
C005	01-97302-00	Assembled PSU PCB	1				
C006	70-010003-0	Heatsink 3	10	S001	66-010003-1	Subfacia	1
C007	69-010008-0	Bus Bar 206	1	S002	75-005001-0	LED Sleeve	9
C008	69-010007-0	Bus Bar 205	1	S003	11-01101-20	Power Switch	1
C009	69-010005-0	Bus Bar 203	1	S004	01-97303-00	Assembled Protect Softclipping Board	1
C010	69-010006-0	Bus Bar 204	1	S005	01-97308-00	Assembled Power Switch Board	1
C011	69-006001-0	Bus Bar 201	1	S006	01-97307-00	Assembled Power LED Board	1
C012	69-010004-0	Bus Bar 202	1				
C013	70-010002-0	Heatsink 2	4	R001	67-010001-0	Rear Panel (C Version) or	1
C014	75-010002-0	Cushion	4		67-010006-0	Rear Panel (AH Version)	1
C015	68-010001-0	Spacer Support (1)	5	R002	66-010010-0	Bracket 6	2
C016	01-97305-01	Assembled Standby PCB	1	R003	11-05202-10	Switch (S402)	1
C017	75-010001-0	Capacitor Holder	1	R004	11-05402-00	Switch (S401)	1
C018	66-010007-0	Bracket 2	7	R005	17-07001-00	12V Trigger In Jack	1
C019	70-010001-1	Heatsink 1	7	R006	17-07003-01	AC Inlets	1
C020	67-010002-2	Bracket 4	7	R007	20-20000-06	Fuse Holder	1
C021	78-005005-0	Insulated Cushion	4	R008	01-97304-00	Assembled Trigger PCB	1
C022	71-001001-0	Binding Post	7	R009	68-010002-0	Spacer Support (2)	2
C023	69-010003-0	Pin	7	R010	71-003002-0	Grd. Post Cap	1
C024	17-01001-10	RCA	7	R011	71-010001-0	Grd. Post Bolt	1
C025	73-010001-0	Rotate Knob	7				
C026	09-01502-00	Pot	7	0001	61-023106-0	Self Screw STB3X6	68
C027	01-97301-00	Assembled AMP Module PCB	7	0002	61-023506-0	Machine Screw MB3X6	5
C028	66-005009-0	TR Clamper	4	0003	61-023108-0	Self Screw STB3X8	63
C029	85-010001-0	Spacer Support	42	0004	61-033106-0	Self Screw STP3×6	4
C030	66-010005-0	Transformer Bracket	1	0005	61-023208-0	Self Screw BTB3X8	63
C031	18-97132-00	Transformer (Toroid) or	1	0006	61-083512-0	Machine Screw MPW3X12	1
	18-97132-01	Transformer (Gloria)	1	0007	61-083518-0	Machine Screw MPW3X18	3
C032	66-010004-0	Metal Disc	1	0008	61-024108-0	Self Screw STB4X8	10
C033	94-010001-0	Transformer (Toroid) Label or	1	0009	61-084108-0	Self Screw STPW4X8	7
	94-010005-0	Transformer (Gloria) Label		0010	61-045215-0	Self Screw TB5X15	12
C034	75-010003-0	Insulated Cell	1	0011	64-110110-0	Bolt M10X110	1
C035	35-01212-00	Fan	3	0012	63-011020-0	Washer, GB97.1-85, Φ10	1
C036	68-010003-0	Fan Cover	3	0013	63-021030-0	Spring Washer 10 GB93-87	1
C037	75-010004-1	Foot (Big)	2	0014	62-011002-0	Nut, M10 GB6170-86	1
C038	75-001008-0	Foot (Small)	2	0015	62-010302-0	Nut, M3, GB6170-86	4
C039	79-008001-0	Foot Pad	4	0016	63-020308-0	Spring Washer, 3mm	4
C040	66-010009-0	Bracket 5	1	0017	63-010303-0	Washer, 3mm	4
C041	01-97301-10	Assembled AMP Module	7	0018	61-013206-0	Bolt	14
				0019	63-030410-0	Serrated Lock Washer	2
F001	67-010003-0	Fascia	1	0020	62-010402-0	Nut M4 GB6170-86	1
F002	67-010005-0	End Cap (R)	1	0021	61-063108-0	STF3X8	2
F003	67-010004-0	End Cap (L)	1	0022	61-223514-0	Machine Screw MB3X14	28
F004	77-009003-1	Power Button	1	0023	61-023215-0	Self Taping Screw BTB3X15	42